

AIO 3.0 - SBRT PRESSURE SYSTEM BRIDGE

Article Nos. : **38222 (low bridge)**
38218 (high bridge)



A. GENERAL PRODUCT INFORMATION

The products referred to in these instructions are medical devices, used for patient positioning and immobilisation in radiation therapy. This product can be used during both the simulation and the treatment stage, including MRI simulation.

To attain an optimal result, it is recommended to use this product in combination with Orfit immobilisation products.

B. PRODUCT DESCRIPTION

These arches are used as a compression device for the abdomen. They clamp onto the SBRT compatible AIO 3.0 base plate ref. 38013. The compression plate is screwed downwards to reach the desired pressure on the abdomen and as such immobilise the abdomen. Information on these other parts (and instructions on how to make the masks) can be found in the respective 'instructions for use' and on www.orfit.com.

C. PRECAUTIONS FOR USE

- This is a fragile product, please handle with care.
- Make sure the device is securely locked onto the SBRT compatible AIO 3.0 base plate ref. 38013 on both sides.
- These pressure system bridges can only be used with the SBRT compatible AIO 3.0 base plate ref. 38013. These bridges are not compatible with other SBRT base plates.

D. INSTALLATION

1. Position the arch in the highest position by opening the locks (A) on both sides and moving the arch vertically upwards to position 5. Close the locks again. (Figure 1)

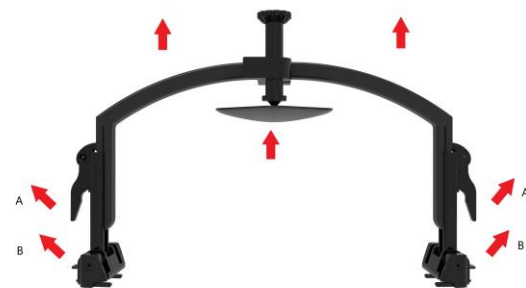

Figure 1

2. Position the screw in the highest position by opening the locking system, pulling the screw upwards and closing the locking system again. (Figure 2)

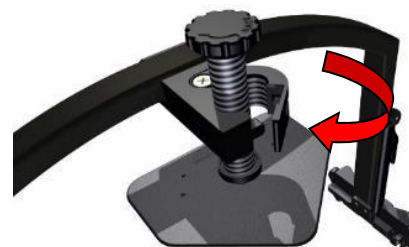

Figure 2

3. Place the pressure plate (32317/2/12) in the correct position on the abdomen of the patient. Be aware that the plate does not exercise pressure on the xiphoid process or ribs to prevent fractures. (Figure 3)



Figure 3

- Position the arch on the baseplate so the screw will touch the pressure plate once you screw it down. Attach the arch to the base plate by opening the clamps (B) on both sides. The arch indexes onto the round holes on top of the base plate and clamps underneath the thin edge. For repositioning purposes write down the location of the arch. The different locations are numbered on the base plate E1 to E34. (Figure 4)

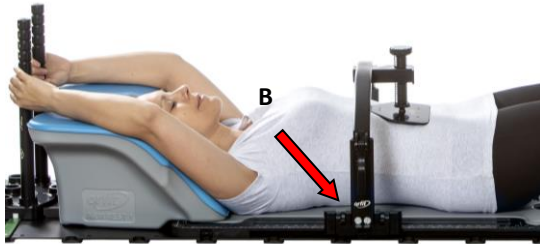

Figure 4

- !! Note that the arch can be positioned with the screw facing the caudal end of the base plate and also the other way around with the screw facing the cranial end of the baseplate. Choose the correct position so the arch is located outside of the treatment field.
- Move the arch vertically downwards until the screw touches the pressure plate by opening the locks (A) on both sides. When you have reached the correct position, close the locks again. When releasing the lock handles make sure to hold the frame to prevent it from sliding down on the patient.

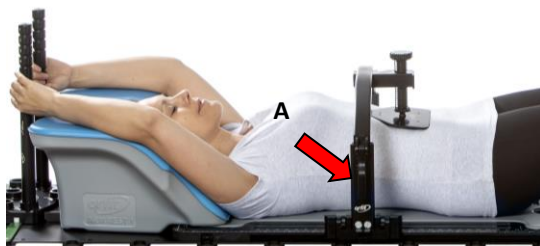

Figure 5

- Fasten the screw until you have reached the desired pressure or height on the abdomen. If the standard screw doesn't reach deep enough, switch to the longer screw.



Figure 6

- The height of the screw can be read from the ruler (Figure 7) or measured for future reference.



Figure 7

- Make sure to note all indexing positions of the arch prior to release. See the patient set-up form 22153E.

In case of an emergency, pressure can be quickly released:

- by opening the vertical screw locking handle and pulling the screw upwards.

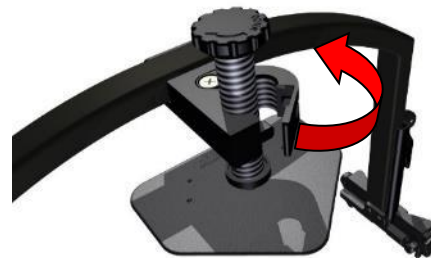

Figure 8

- by releasing the arch to base plate handles and pulling the arch backwards.



Figure 9

Available arch types (with the standard screw):

Art. 38222

Art. 38218

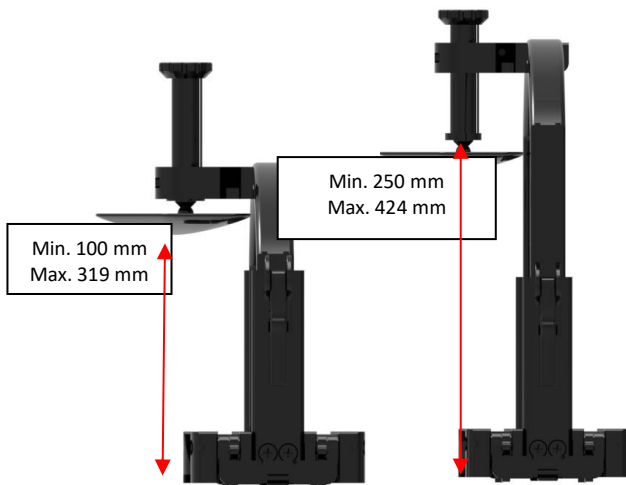

Figure 10

The image below shows the low arch 38222 at position 0 in a bore with a diameter of 700mm.



The image below shows the high arch 38218 at position 0 in a bore with a diameter of 700mm.



E. STORAGE

Always store the product in a safe place to prevent it from getting damaged.

Store the arch between +10°C (50°F) and 40°C (122°F).

F. PROPERTIES

E.1. Physical Properties 38222

Dimensions: 195 w x 330 h x 630 mm long

Weight: 2.12 kg

Materials: HPL, POM, PEEK, PA

Average density: 1,4 gr/cm³

E.2. Physical Properties 38218

Dimensions: 195 w x 435 h x 630 mm long

Weight: 2,4 kg

Materials: HPL, POM, PEEK, PA

Average density: 1,4 gr/cm³

Both arches are made entirely of electrically non-conductive, non-metallic and non-magnetic materials and is MRI safe.



E.3. Mechanical Properties

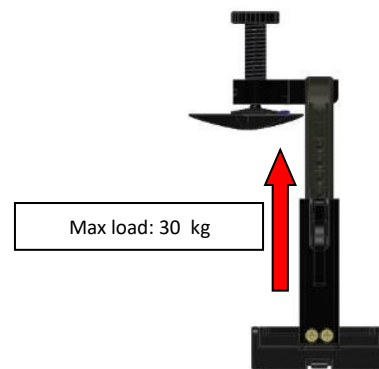

Figure 11

Max. load is the same for each type/size of compression arch. Component failure can occur when max load is exceeded typically because the patient exerts high forces on the device (panic, coughing, vomiting, etc.). Component failure is not harmful for the patient.

G. MAINTENANCE AND WASTE MANAGEMENT

This product can be cleaned and disinfected by means of an isopropanol based disinfectant, applied with a soft cloth. If unsure about the cleaning fluid, do not use. **Never use aerosol sprays, corrosive cleaning agents, solvents or abrasive detergents.**

Periodic checks of the product should be done to insure the parts are not worn and require repair or replacement. **Do not attempt to make repairs yourself.** Do not use the product when damaged. Contact your distributor if there are any questions or concerns.

The product can be disposed of with household waste.

H. ADDITIONAL INFORMATION

For additional information such as distributor contact information, product brochures, Safety Data Sheets and regulatory information, please visit our website www.orfit.com.

Note:

It is prohibited to make alterations to this text without prior approval from Orfit Industries. RAYCAST[®] and EFFICAST[®] are registered trademarks of ORFIT Industries.



ORFIT INDUSTRIES
Vosveld 9A | B-2110 Wijnegem | Belgium
T (+32) (0)3 326 20 26
welcome@orfit.com

www.orfit.com



Ref. No. 50258
VERSION 1
LAST UPDATE: 12/05/2022
REVISION DATE: 12/05/2024